

环球 A系列短节距精密滚子链
Short pitch precision roller chains (A series)

单排
Single Row

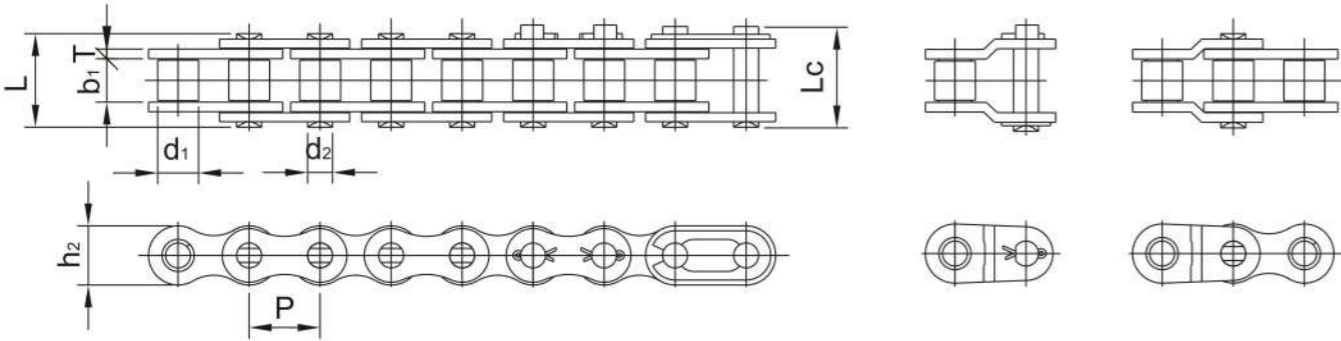

ISO/ DIN 链号 ISO/ DIN Chain No.	NSI 链号 NSI Chain No.	节距 Pitch P	滚子直径 Roller diameter d ₁	内节内宽 Width between inner plates b ₁	销轴直径 Pin diameter d ₂	销轴长度 Pin length L	内链板高度 Inner plate depth Lc	排距 Transverse Pitch h ₂	链板厚度 Plate thickness T	抗拉强度 Ultimate tensile strength Q(ISO/DIN) min	平均抗拉强度 Average tensile strength Q ₀	每米重量 Weight per meter q	
		mm	mm	mm	mm	mm	mm	mm	mm	kN	kN	kg/m	
*04C-1	*25	6.35	3.30	3.10	2.31	8.00	9.90	6.02	-	0.80	3.50	4.40	0.14
*06C-1	*35	9.525	5.08	4.68	3.58	12.40	14.40	8.70	-	1.30	7.90	10.40	0.33
085-1	41	12.70	7.77	6.25	3.58	13.75	16.00	9.91	-	1.25	6.70/6.80	11.80	0.41
08A-1	40	12.70	7.95	7.85	3.96	16.60	19.10	12.07	-	1.50	13.80/14.10	17.80	0.62
10A-1	50	15.875	10.16	9.40	5.08	20.70	23.30	15.09	-	2.06	21.80/22.20	28.00	1.02
12A-1	60	19.05	11.91	12.57	5.94	25.90	28.60	18.08	-	2.44	31.10/31.80	39.00	1.50
16A-1	80	25.40	15.88	15.75	7.92	32.70	38.00	24.13	-	3.26	55.60/56.70	71.50	2.60
20A-1	100	31.75	19.05	18.90	9.53	41.10	44.90	30.18	-	4.00	86.70/88.50	102.00	3.91
24A-1	120	38.10	22.23	25.22	11.10	50.80	56.10	36.20	-	4.80	124.60/127.00	156.90	5.62
28A-1	140	44.45	25.40	25.22	12.70	54.90	60.80	42.24	-	5.65	169.00/172.40	210.80	7.50
32A-1	160	50.80	28.58	31.55	14.27	65.50	72.60	48.26	-	6.45	222.40/226.80	269.70	10.10
36A-1	180	57.15	35.71	35.48	17.46	72.80	83.00	54.31	-	7.25	280.20	327.80	13.45
40A-1	200	63.50	39.68	37.85	19.85	80.30	90.50	60.33	-	8.00	347.00/353.80	410.00	16.15
48A-1	240	76.20	47.63	47.35	23.81	95.50	106.00	72.39	-	9.50	500.40/510.30	585.40	23.20

*套筒链:表中滚子直径d₁为套筒直径。
*Bush chains: d₁ indicate the external diameter of the bushing.

双排
Double Row

A系列短节距精密滚子链 环球
Short pitch precision roller chains (A series)

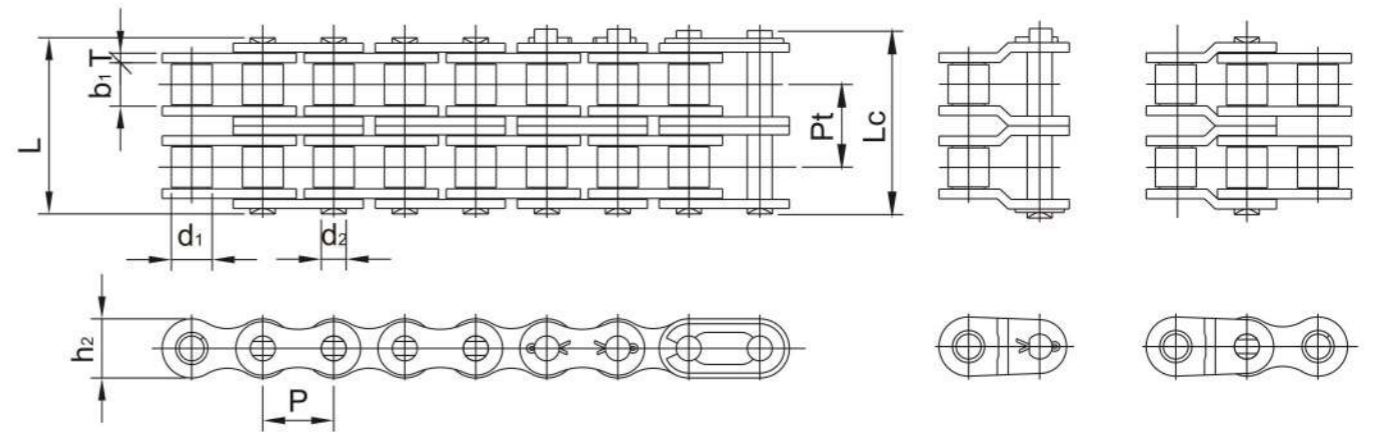

ISO/DIN 链号 ISO/DIN Chain No.	ANSI 链号 ANSI Chain No.	节距 Pitch P	滚子直径 Roller diameter d ₁	内节内宽 Width between inner plates b ₁	销轴直径 Pin diameter d ₂	销轴长度 Pin length L	内链板高度 Inner plate depth Lc	排距 Transverse pitch h ₂	链板厚度 Plate thickness T	抗拉强度 Ultimate tensile strength Q(ISO/DIN) min	平均抗拉强度 Average tensile strength Q ₀	每米重量 Weight per meter q	
		mm	mm	mm	mm	mm	mm	mm	mm	kN	kN	kg/m	
*04C-2	*25-2	6.35	3.30	3.10	2.31	14.50	16.50	6.02	6.40	0.80	7.00	8.80	0.28
*06C-2	*35-2	9.525	5.08	4.68	3.58	22.50	24.50	8.70	10.13	1.30	15.80	20.80	0.63
08A-2	40-2	12.70	7.95	7.85	3.96	31.00	33.50	12.07	14.38	1.50	27.60/28.20	35.60	1.12
10A-2	50-2	15.875	10.16	9.40	5.08	38.90	41.30	15.09	18.11	2.06	43.60/44.40	56.00	2.00
12A-2	60-2	19.05	11.91	12.57	5.94	48.80	51.50	18.08	22.78	2.44	62.30/63.60	82.40	2.92
16A-2	80-2	25.40	15.88	15.75	7.92	62.70	67.10	24.13	29.29	3.26	111.20/113.40	143.00	5.15
20A-2	100-2	31.75	19.05	18.90	9.53	76.40	83.10	30.18	35.76	4.00	173.50/177.00	204.00	7.80
24A-2	120-2	38.10	22.23	25.22	11.10	96.30	101.60	36.20	45.44	4.80	249.10/254.00	313.80	11.70
28A-2	140-2	44.45	25.40	25.22	12.70	103.60	109.40	42.24	48.87	5.65	338.10/344.80	421.70	15.14
32A-2	160-2	50.80	28.58	31.55	14.27	123.30	130.20	48.26	58.55	6.45	444.80/453.60	539.40	20.14
36A-2	180-2	57.15	35.71	35.48	17.46	138.60	148.50	54.31	65.84	7.25	560.50	655.70	29.22
40A-2	200-2	63.50	39.68	37.85	19.85	151.90	161.50	60.33	71.55	8.00	693.90/707.60	820.00	32.24
48A-2	240-2	76.20	47.63	47.35	23.81	183.40	193.90	72.39	87.83	9.50	1000.80/1020.60	1170.80	45.23

*套筒链:表中滚子直径d₁为套筒直径。
*Bush chains: d₁ indicate the external diameter of the bushing.

环球 A系列短节距精密滚子链
Short pitch precision roller chains (A series)

叁排
Three Rows

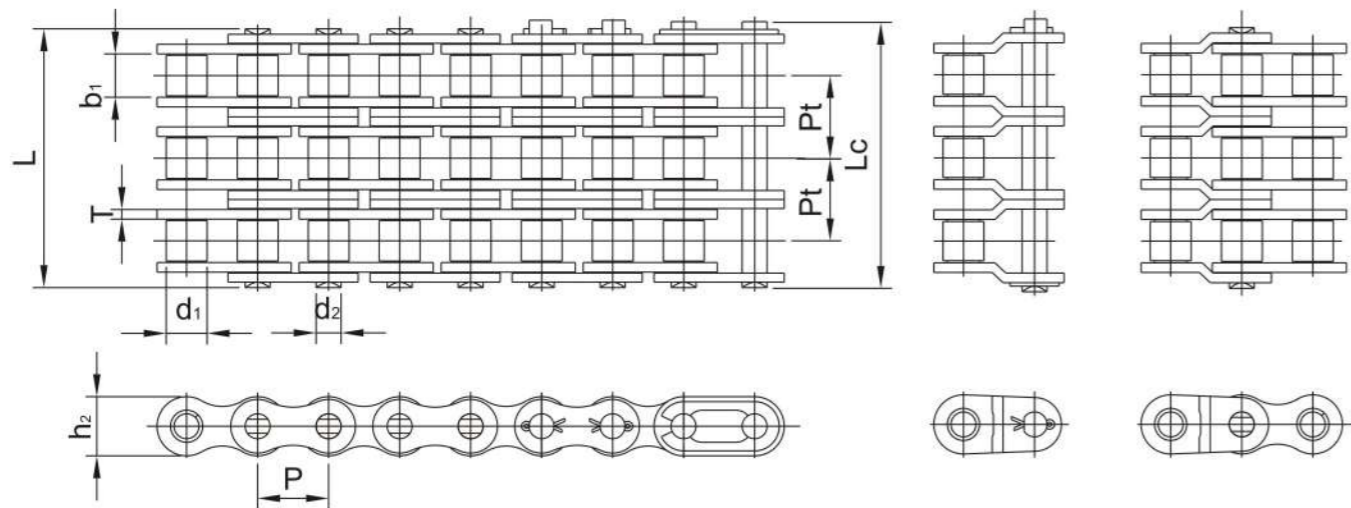

ISO/ DIN 链号 ISO/ DIN Chain No.	NSI 链号 Chain No.	节距 Pitch P	滚子直径 Roller diameter d ₁	内节内宽 Width between inner plates b ₁	销轴直径 Pin diameter d ₂	销轴长度 Pin length L	销轴长度 Pin length L _c	内链板高度 Inner plate depth h ₂	排距 ransverse pitch Pt	链板厚度 Plate thickness T	抗拉强度 Ultimate tensile strength Q (ISO/DIN) min kN	平均抗拉强度 Average tensile strength Q ₀ kN	每米重量 Weight per meter q kg/m
*06C-3	*35-3	9.525	5.08	4.68	3.58	32.70	34.70	8.70	10.13	1.30	23.70	30.00	1.05
08A-3	40-3	12.70	7.95	7.85	3.96	45.40	48.00	12.07	14.38	1.50	41.40/42.30	51.20	1.90
10A-3	50-3	15.875	10.16	9.40	5.08	57.00	59.80	15.09	18.11	2.06	65.40/66.60	82.00	3.09
12A-3	60-3	19.05	11.91	12.57	5.94	71.50	75.60	18.08	22.78	2.44	93.40/95.40	115.00	4.54
16A-3	80-3	25.40	15.88	15.75	7.92	91.70	96.80	24.13	29.29	3.26	166.80/170.10	208.00	7.89
20A-3	100-3	31.75	19.05	18.90	9.53	112.20	117.20	30.18	35.76	4.00	260.20/265.50	310.00	11.77
24A-3	120-3	38.10	22.23	25.22	11.10	141.70	148.30	36.20	45.44	4.80	373.70/381.00	470.70	17.53
28A-3	140-3	44.45	25.40	25.22	12.70	152.20	158.30	42.24	48.87	5.65	507.10/517.20	632.50	22.20
32A-3	160-3	50.80	28.58	31.55	14.27	181.80	188.60	48.26	58.55	6.45	667.20/680.40	809.00	30.02
36A-3	180-3	57.15	35.71	35.48	17.46	204.40	214.50	54.31	65.84	7.25	840.70	983.60	38.22
40A-3	200-3	63.50	39.68	37.85	19.85	223.50	232.90	60.33	71.55	8.00	1040.90/1061.40	1230.00	49.03
48A-3	240-3	76.20	47.63	47.35	23.81	271.30	281.80	72.39	87.83	9.50	1501.30/1530.90	1756.20	71.60

*套筒链:表中滚子直径d₁为套筒直径。
*Bush chains: d₁ indicate the external diameter of the bushing.

单排
Single Row

B系列短节距精密滚子链 环球
Short pitch precision roller chains (B series)

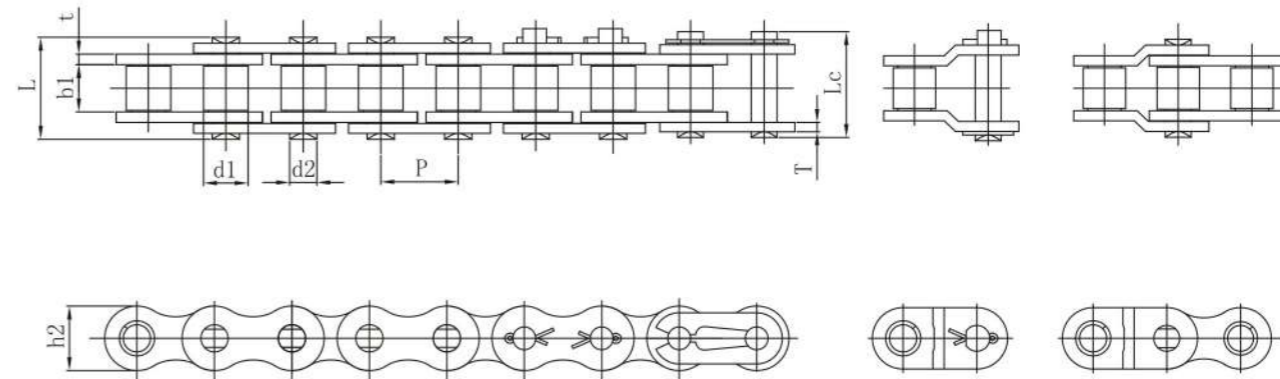

ISO/DIN 链号 ISO/DIN Chain No.	节距 Pitch P	滚子直径 Roller diameter d ₁	内节内宽 Width between inner plates b ₁	销轴直径 Pin diameter d ₂	销轴长度 Pin length L	销轴长度 Pin length L _c	内链板高度 Inner plate depth h ₂	链板厚度 Plate thickness T	排距 Transverse pitch Pt	抗拉强度 Ultimate tensile strength Q (ISO/DIN) min kN	平均抗拉强度 Average tensile strength Q ₀ kN	每米重量 Weight per meter q kg/m
05B-1	8.00	5.00	3.00	2.31	8.20	8.90	7.10	0.80	-	4.40/5.00	5.90	0.20
*06B-1	9.525	6.35	5.72	3.28	13.15	15.15	8.26	1.34	-	8.90/9.00	10.30	0.41
08B-1	12.70	8.51	7.75	4.45	16.95	19.05	11.81	1.60	-	17.80/18.00	19.60	0.69
10B-1	15.875	10.16	9.65	5.08	19.50	22.0	14.73	1.70	-	22.20/22.40	27.50	0.93
12B-1	19.05	12.07	11.68	5.72	22.50	25.10	16.13	1.85	-	28.90/29.00	33.30	1.15
16B-1	25.40	15.88	17.02	8.28	36.10	41.50	21.08	4.09/3.10	-	60.00	71.00	2.71
20B-1	31.75	19.05	19.58	10.19	42.40	47.60	26.42	4.60/3.60	-	95.00	101.80	3.70
24B-1	38.10	25.40	25.40	14.63	53.40	57.10	33.40	5.80/4.80	-	160.00	176.00	7.10
28B-1	44.45	27.94	30.99	15.90	65.10	69.40	37.08	7.50/6.50	-	200.00	215.60	8.50
32B-1	50.80	29.21	30.99	17.81	66.00	69.50	42.29	7.00/6.00	-	250.00	280.30	10.25
40B-1	63.50	39.37	38.10	22.89	82.60	91.30	52.96	8.50/7.50	-	355.00	392.00	16.35
48B-1	76.20	48.26	45.72	29.24	99.10	109.60	63.88	11.70/10.00	-	560.00	599.20	25.00
56B-1	88.90	53.98	53.34	34.32	114.6	123.0	77.80	13.5/12.0	-	850.0	940.0	35.78
64B-1	101.60	63.50	60.96	39.40	130.0	138.5	90.17	15.0/13.0	-	1120.0	1240.0	46.00
72B-1	114.30	72.39	68.58	44.48	147.4	156.4	103.60	17.0/15.0	-	1400.0	1550.0	60.80

*直链板
*Straight side plates

环球 B系列短节距精密滚子链
Short pitch precision roller chains (B series)

双排
Double Row

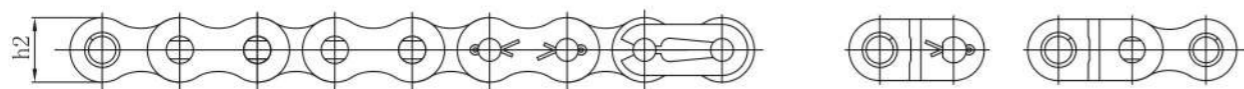
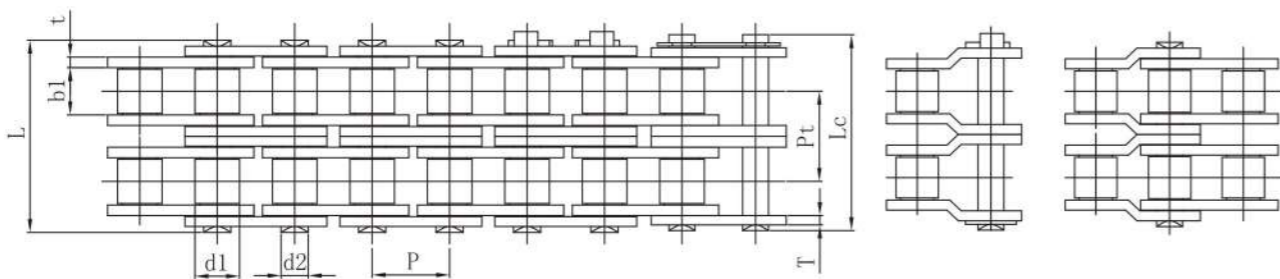

ISO/DIN 链号 ISO/DIN Chain No.	节距 Pitch P	滚子直径 Roller diameter d ₁	内节内宽 Width between inner plates b ₁	销轴直径 Pin diameter d ₂	销轴长度 Pin length L Lc		内链板高度 Inner plate depth h ₂	链板厚度 Plate thickness t/T	排距 Transverse pitch Pt	抗拉强度 Ultimate tensile strength Q (ISO/DIN) min kN	平均抗拉强度 Average tensile strength Q ₀	每米重量 Weight per meter q ≈ kg/m
05B-2	8.00	5.00	3.00	2.31	13.90	14.50	7.10	0.80	5.64	7.80	10.20	0.33
*06B-2	9.525	6.35	5.72	3.28	23.40	27.10	8.26	1.34	10.24	16.90	18.10	0.74
08B-2	12.70	8.51	7.75	4.45	31.00	33.00	11.81	1.60	13.92	31.10/32.00	37.40	1.34
10B-2	15.875	10.16	9.65	5.08	36.10	38.60	14.73	1.70	16.59	44.50	54.20	1.84
12B-2	19.05	12.07	11.68	5.72	42.00	44.40	16.13	1.85	19.46	57.80	66.60	2.31
16B-2	25.40	15.88	17.02	8.28	68.00	73.40	21.08	4.09/3.10	31.88	106.00	126.50	5.42
20B-2	31.75	19.05	19.58	10.19	79.70	83.60	26.42	4.60/3.60	36.45	170.00	210.00	7.20
24B-2	38.10	25.40	25.40	14.63	101.80	105.42	33.40	5.80/4.80	48.36	280.00	305.50	13.40
28B-2	44.45	27.94	30.99	15.90	124.70	128.96	37.08	7.50/6.50	59.56	360.00	390.50	16.60
32B-2	50.80	29.21	30.99	17.81	124.60	128.05	42.29	7.00/6.00	58.55	450.00	487.50	21.00
40B-2	63.50	39.37	38.10	22.89	154.50	163.80	52.96	8.50/7.50	72.29	630.00	680.20	32.00
48B-2	76.20	48.26	45.72	29.24	190.40	200.90	63.88	11.70/10.00	91.21	1000.00	1070.00	50.00
56B-2	88.90	53.98	53.34	34.32	221.2	229.6	77.80	13.5/12.0	106.6	1600.00	1760.00	71.48
64B-2	101.60	63.50	60.96	39.40	249.9	258.4	90.17	15.0/13.0	119.89	2000.00	2200.00	91.00
72B-2	114.30	72.39	68.58	44.48	283.7	292.7	103.60	17.0/15.0	136.27	2500.00	2750.00	120.40

*直链板
*Straight side plates

叁排
Three Rows

B系列短节距精密滚子链 环球
Short pitch precision roller chains (B series)

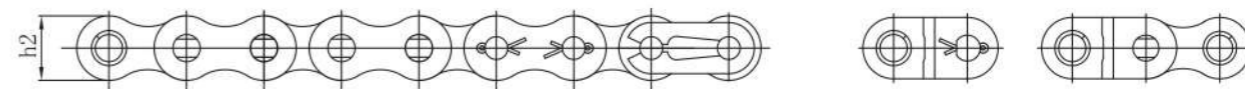
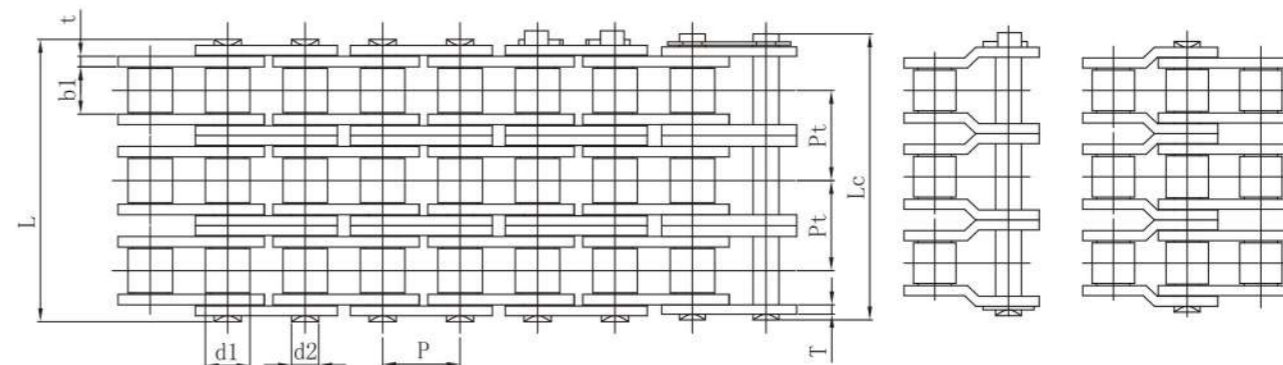

ISO/DIN 链号 ISO/DIN Chain No.	节距 Pitch P	滚子直径 Roller diameter d ₁	内节内宽 Width between inner plates b ₁	销轴直径 Pin diameter d ₂	销轴长度 Pin length L Lc		内链板高度 Inner plate depth h ₂	链板厚度 Plate thickness t/T	排距 Transverse pitch Pt	抗拉强度 Ultimate tensile strength Q (ISO/DIN) min kN	平均抗拉强度 Average tensile strength Q ₀	每米重量 Weight per meter q ≈ kg/m
*06B-3	9.525	6.35	5.72	3.28	33.50	37.30	8.26	1.34	10.24	24.90	29.80	1.16
08B-3	12.70	8.51	7.75	4.45	44.90	47.20	11.81	1.60	13.92	44.50/47.50	50.20	2.03
10B-3	15.875	10.16	9.65	5.08	52.70	55.60	14.73	1.70	16.59	66.70	79.80	2.77
12B-3	19.05	12.07	11.68	5.72	61.50	65.20	16.13	1.85	19.46	86.70	101.80	3.46
16B-3	25.40	15.88	17.02	8.28	99.80	105.30	21.08	4.09/3.10	31.88	160.00	190.00	8.13
20B-3	31.75	19.05	19.58	10.19	114.55	121.20	26.42	4.60/3.60	36.45	250.00	276.20	10.82
24B-3	38.10	25.40	25.40	14.63	150.20	153.82	33.40	5.80/4.80	48.36	425.00	480.00	20.10
28B-3	44.45	27.94	30.99	15.90	184.30	188.52	37.08	7.50/6.50	59.56	530.00	580.00	24.92
32B-3	50.80	29.21	30.99	17.81	184.01	186.60	42.29	7.00/6.00	58.55	670.00	720.20	31.56
40B-3	63.50	39.37	38.10	22.89	226.80	236.10	52.96	8.50/7.50	72.29	950.00	1020.00	48.10
48B-3	76.20	48.26	45.72	29.24	281.60	292.10	63.88	11.70/10.00	91.21	1500.00	1590.00	75.00
56B-3	88.90	53.98	53.34	34.32	327.8	336.20	77.80	13.5/12.00	106.6	2240.00	2240.00	107.18
64B-3	101.60	63.50	60.96	39.40	369.8	378.30	90.17	15.0/13.00	119.89	3000.00	3300.00	136.00
72B-3	114.30	72.39	68.58	44.48	420.0	429.00	103.60	17.0/15.00	136.27	3750.00	4125.00	180.00

*直链板
*Straight side plates

环球 重载系列滚子链
Heavy duty roller chains

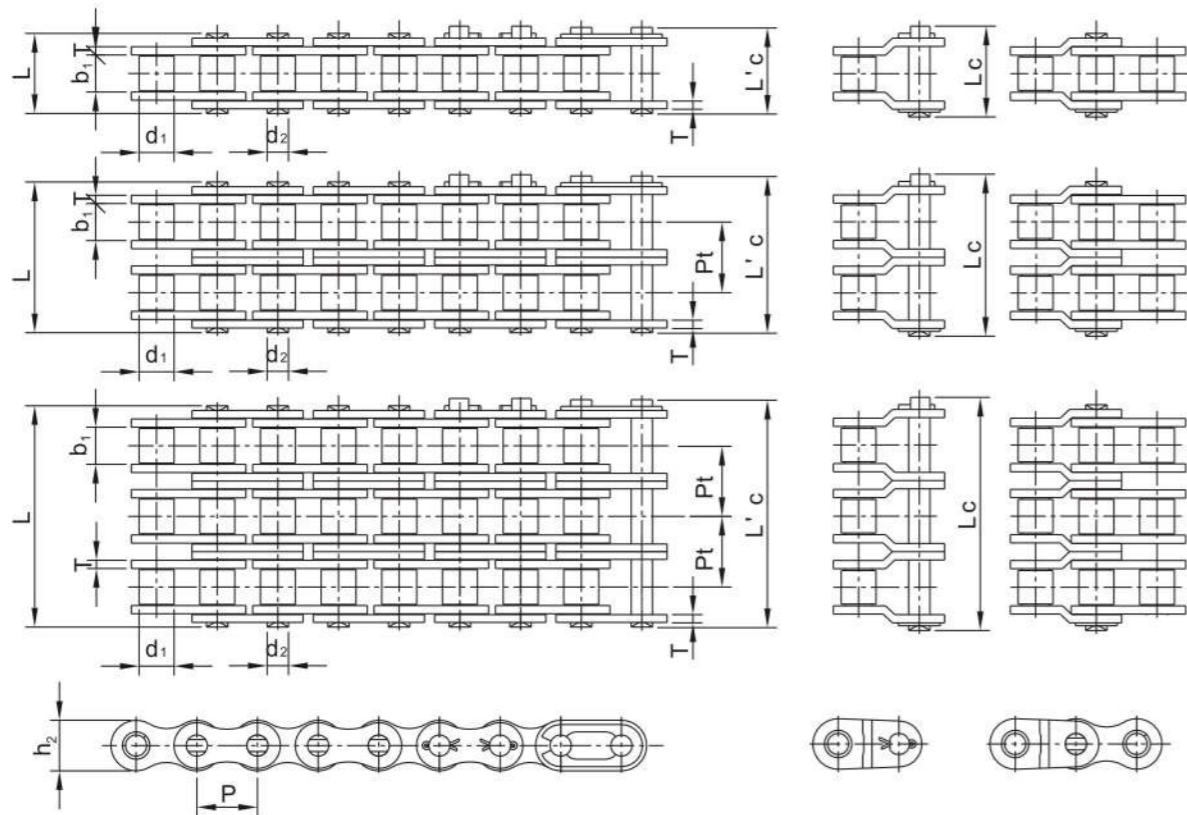

ISO/DIN 链号 ISO/DIN Chain No.	ANSI 链号 ANSI Chain No.	节距 Pitch	滚子直径 Roller diameter	内节内宽 Width between inner plates	销轴直径 Pin diameter	销轴长度 Pin length		内链板高度 Inner plate depth	排距 Transverse pitch	链板厚度 Plate thickness	抗拉强度 Ultimate tensile strength	平均抗拉强度 Average tensile strength	每米重量 Weight per meter
		P	d ₁ max	b ₁ min	d ₂ max	L max	L _c max	h ₂ max	Pt	T	Q(ISO/DIN) min	Q ₀	q
		mm	mm	mm	mm	mm	mm	mm	mm	mm	kN	kN	kg/m
08AH-1	40H	12.70	7.95	7.85	3.96	18.20	19.70	12.00	-	2.06	13.80/14.10	20.40	0.82
10AH-1	50H	15.875	10.16	9.40	5.08	22.10	24.90	15.09	-	2.44	21.80/22.20	29.80	1.25
12AH-1	60H	19.05	11.91	12.57	5.94	29.90	34.50	18.08	-	3.26	31.10/31.80	41.00	1.87
16AH-1	80H	25.40	15.88	15.75	7.92	36.60	42.00	24.13	-	4.00	55.60/56.70	72.10	3.10
20AH-1	100H	31.75	19.05	18.90	9.53	44.10	50.20	30.18	-	4.80	86.70/88.50	106.20	4.38
24AH-1	120H	38.10	22.23	25.22	11.10	53.80	60.40	36.20	-	5.65	24.60/127.00	156.70	6.60
12AH-2	60H-2	19.05	11.91	12.57	5.94	56.00	60.60	18.08	26.11	3.26	62.30/63.60	85.00	3.71
16AH-2	80H-2	25.40	15.88	15.75	7.92	69.20	74.60	24.13	32.59	4.00	111.20/113.40	144.20	6.15
20AH-2	100H-2	31.75	19.05	18.90	9.53	83.20	89.10	30.18	39.09	4.80	173.50/177.00	212.40	8.67
24AH-2	120H-2	38.10	22.23	25.22	11.10	102.7	109.3	36.20	48.87	5.65	249.10/254.00	310.50	13.13
12AH-3	60H-3	19.05	11.91	12.57	5.94	82.10	86.70	18.08	26.11	3.26	93.40/95.40	120.00	5.54
16AH-3	80H-3	25.40	15.88	15.75	7.92	101.8	107.2	24.13	32.59	4.00	166.80/170.10	210.20	9.42
20AH-3	100H-3	31.75	19.05	18.90	9.53	122.3	128.4	30.18	39.09	4.80	260.20/265.50	316.80	12.96
24AH-3	120H-3	38.10	22.23	25.22	11.10	151.5	158.1	36.20	48.87	5.65	373.70/381.00	458.20	19.64

注: L_c销轴长度小于Lc
Note: L_c<Lc.

重载系列滚子链 环球
Heavy duty roller chains UNIVERSAL TECHNOLOGY

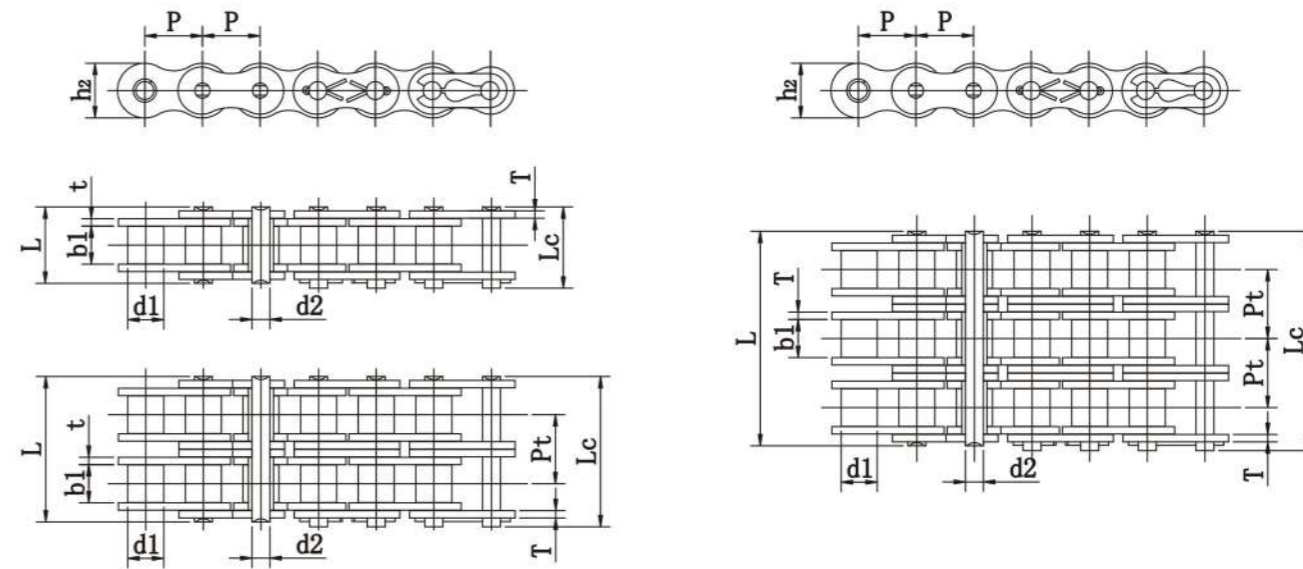

ISO/DIN 链号 ISO/DIN Chain No.	ANSI 链号 ANSI Chain No.	节距 Pitch	滚子直径 Roller diameter	内节内宽 Width between inner plates	销轴直径 Pin diameter	销轴长度 Pin Length		内链板高度 Inner plate depth	排距 Transverse pitch	链板厚度 Plate thickness	抗拉强度 Ultimate tensile strength	平均抗拉强度 Average tensile strength	每米重量 Weight per meter
		P	d ₁ max	b ₁ min	d ₂ max	L max	L _c max	h ₂ max	Pt	t/T	Q min	Q ₀	q
		mm	mm	mm	mm	mm	mm	mm	mm	mm	kN	kN	kg/m
28AH-1	140H	44.45	25.40	25.22	12.70	57.6	62.2	41.00	-	6.40	172.4	217.3	8.30
32AH-1	160H	50.80	28.58	31.55	14.27	68.2	73.0	47.80	-	7.20	226.8	285.8	10.30
36AH-1	180H	57.15	35.71	35.48	17.46	75.9	81.6	53.60	-	8.00	281.0	341.8	14.83
40AH-1	200H	63.50	39.68	37.85	19.85	86.6	93.5	60.00	-	9.50	353.8	444.5	19.16
28AH-2	140H-2	44.45	25.40	25.22	12.70	109.8	114.4	41.00	52.20	6.40	344.8	437.7	16.60
32AH-2	160H-2	50.80	28.58	31.55	14.27	130.1	134.9	47.80	61.90	7.20	453.6	571.6	20.20
40AH-2	200H-2	63.50	39.68	37.85	19.85	164.9	171.8	60.00	78.31	9.50	707.6	894.9	38.11
28AH-3	140H-3	44.45	25.40	25.22	12.70	162.0	166.6	41.00	52.20	6.40	517.2	598.4	24.90
32AH-3	160H-3	50.80	28.58	31.55	14.27	192.0	196.8	47.80	61.90	7.20	680.4	787.3	30.10
40AH-3	200H-3	63.50	39.68	37.85	19.85	243.2	250.1	60.00	78.31	9.50	1061.4	1228.2	57.06

环球 A系列开口销型短节距精密滚子链
Cotter pin typeshort pitch precision roller chains (A series)

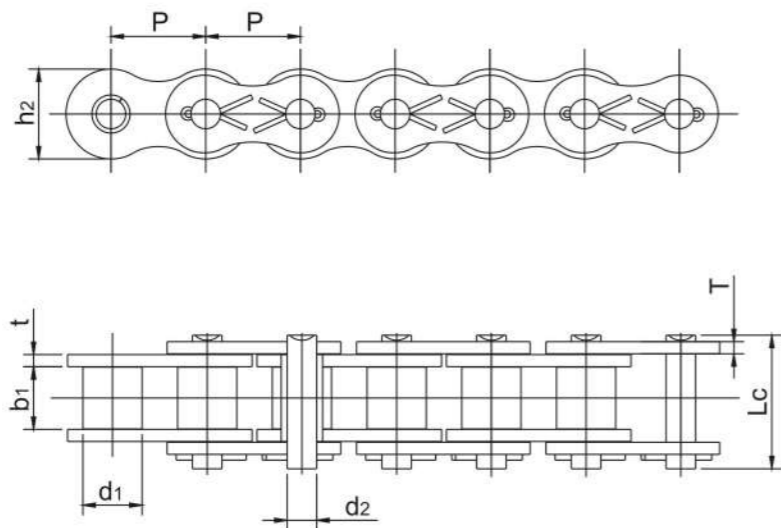

ISO/DIN 链号 ISO/DIN Chain No.	ANSI 链号 ANSI Chain No.	节距 Pitch	滚子直径 Roller diameter	内节内宽 Width between inner plates	销轴直径 Pin diameter	销轴长度 Pin Length	内链板高度 Inner plate depth	排距 Transverse pitch	链板厚度 Plate thickness	抗拉强度 Ultimate tensile strength	平均抗拉 强度 Average tensile strength	每米重量 Weight per meter
		P	d1 max	b1 min	d2 max	Lc max	h2 max	Pt	t/T	Q(ISO/DIN) min	Q 0	q ≈
		mm	mm	mm	mm	mm	mm	mm	mm	KN	KN	Kg/m
10A-1	50	15.875	10.16	9.40	5.09	22.59	15.09	-	2.00	21.80/22.20	29.4	1.02
12A-1	60	19.05	11.91	12.57	5.96	27.75	18.10	-	2.40	31.30/31.80	41.5	1.50
16A-1	80	25.40	15.88	15.75	7.94	35.60	24.13	-	3.20	55.60/56.70	71.5	2.60
20A-1	100	31.75	19.05	18.90	9.54	42.60	30.17	-	4.00	87.00/88.50	109.2	3.91
24A-1	120	38.10	22.23	25.22	11.11	53.51	36.20	-	4.80	125.00/127.00	156.9	5.62
28A-1	140	44.45	25.40	25.22	12.71	58.21	42.23	-	5.65	170.00/172.40	212.0	7.50
32A-1	160	50.80	28.58	31.55	14.29	69.08	48.26	-	6.45	223.00/226.80	269.7	10.10
36A-1	180	57.15	35.71	35.48	17.46	78.45	54.30	-	7.25	281.0	327.8	13.45
40A-1	200	63.50	39.68	37.85	19.85	85.15	60.33	-	8.00	347.00/353.80	410.0	16.15
48A-1	240	76.20	47.63	47.35	23.81	100.71	72.39	-	9.50	500.00/510.30	585.4	23.20

A系列开口销型短节距精密滚子链 环球
Cotter pin typeshort pitch precision roller chains (A series)

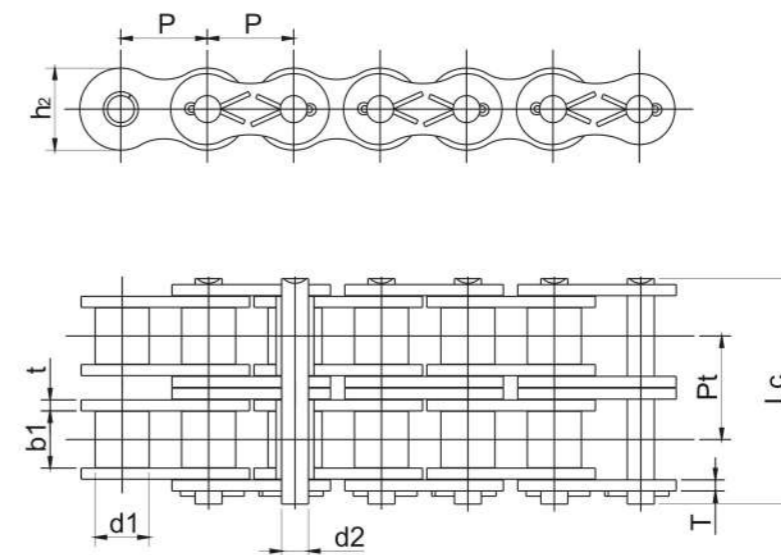

ISO/DIN 链号 ISO/DIN Chain No.	ANSI 链号 ANSI Chain No.	节距 Pitch	滚子直径 Roller diameter	内节内宽 Width between inner plates	销轴直径 Pin diameter	销轴长度 Pin Length	内链板高度 Inner plate depth	排距 Transverse pitch	链板厚度 Plate thickness	抗拉强度 Ultimate tensile strength	平均抗拉 强度 Average tensile strength	每米重量 Weight per meter
		P	d1 max	b1 min	d2 max	Lc max	h2 max	Pt	t/T	Q(ISO/DIN) min	Q0	q ≈
		mm	mm	mm	mm	mm	mm	mm	mm	KN	KN	Kg/m
10A-2	50-2	15.875	10.16	9.40	5.09	40.70	15.09	18.11	2.00	43.60/44.40	56.0	2.00
12A-2	60-2	19.05	11.91	12.57	5.96	50.53	18.10	22.78	2.40	62.60/63.60	82.4	2.92
16A-2	80-2	25.40	15.88	15.75	7.94	64.89	24.13	29.29	3.20	111.20/113.40	143.0	5.15
20A-2	100-2	31.75	19.05	18.90	9.54	78.36	30.17	35.76	4.00	174.00/177.00	204.0	7.80
24A-2	120-2	38.10	22.23	25.22	11.11	98.95	36.20	45.44	4.80	250.00/254.00	313.8	11.70
28A-2	140-2	44.45	25.40	25.22	12.71	107.08	42.23	48.87	5.65	340.00/344.80	421.7	15.14
32A-2	160-2	50.80	28.58	31.55	14.29	127.63	48.26	58.55	6.45	446.00/453.60	539.4	20.14
36A-2	180-2	57.15	35.71	35.48	17.46	144.29	54.30	65.84	7.25	562.0	655.7	29.22
40A-2	200-2	63.50	39.68	37.85	19.85	156.70	60.33	71.55	8.00	694.00/707.60	820.0	32.24
48A-2	240-2	76.20	47.63	47.35	23.81	188.54	72.39	87.83	9.50	1000.0/1020.6	1170.8	45.23

环球 A系列开口销型短节距精密滚子链
Cotter pin typeshort pitch precision roller chains (A series)

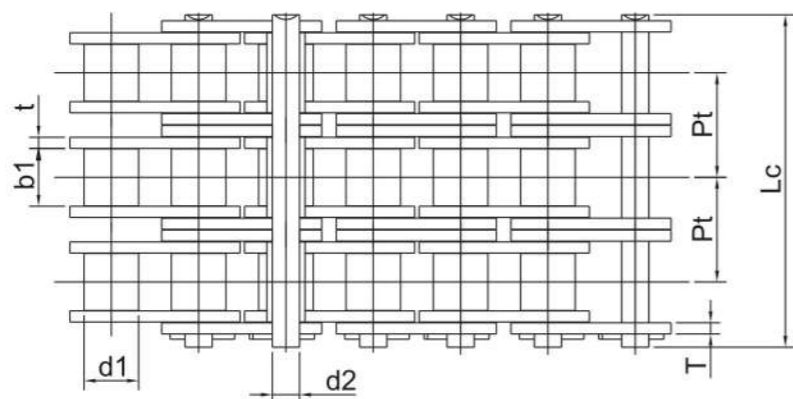
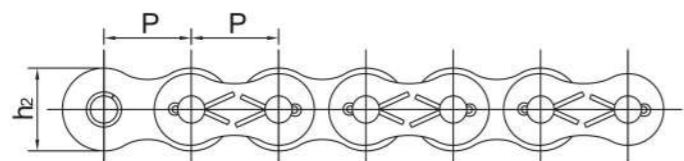

ISO/DIN 链号 Chain No.	ANSI 链号 Chain No.	节距 Pitch	滚子直径 Roller diameter	内节内宽 Width between inner plates	销轴直径 Pin diameter	销轴长度 Pin Length	内链板高度 Inner plate depth	排距 Transverse pitch	链板厚度 Plate thickness	抗拉强度 Ultimate tensile strength	平均抗拉强度 Average tensile strength	每米重量 Weight per meter
		P	d1 max	b1 min	d2 max	Lc max	h2 max	Pt	t/T	Q(ISO/DIN) min	Q0	q =
		mm	mm	mm	mm	mm	mm	mm	mm	KN	KN	Kg/m
10A-3	50-3	15.875	10.16	9.40	5.09	58.81	15.09	18.11	2.00	65.40/66.60	82.0	3.09
12A-3	60-3	19.05	11.91	12.57	5.96	73.31	18.10	22.78	2.40	93.90/95.40	115.0	4.54
16A-3	80-3	25.40	15.88	15.75	7.94	94.18	24.13	29.29	3.20	166.80/170.10	208.0	7.89
20A-3	100-3	31.75	19.05	18.90	9.54	114.12	30.17	35.76	4.00	261.00/265.50	310.0	11.77
24A-3	120-3	38.10	22.23	25.22	11.11	144.39	36.20	45.44	4.80	375.00/381.00	470.7	17.53
28A-3	140-3	44.45	25.40	25.22	12.71	155.95	42.23	48.87	5.65	510.00/517.20	632.5	22.20
32A-3	160-3	50.80	28.58	31.55	14.29	186.18	48.26	58.55	6.45	669.00/680.40	809.0	30.02
36A-3	180-3	57.15	35.71	35.48	17.46	210.13	54.30	65.84	7.25	843.0	983.6	38.22
40A-3	200-3	63.50	39.68	37.85	19.85	228.25	60.33	71.55	8.00	1041.0/1061.4	1230.0	49.03
48A-3	240-3	76.20	47.63	47.35	23.81	276.37	72.39	87.83	9.50	1500.0/1530.9	1756.2	71.6

加重系列开口销型短节距精密滚子链
Heavy duty series cotter pin type roller chains

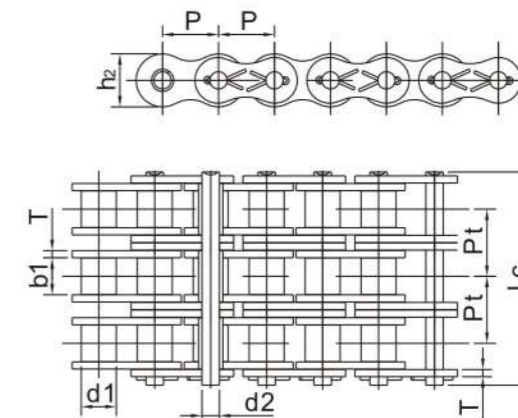
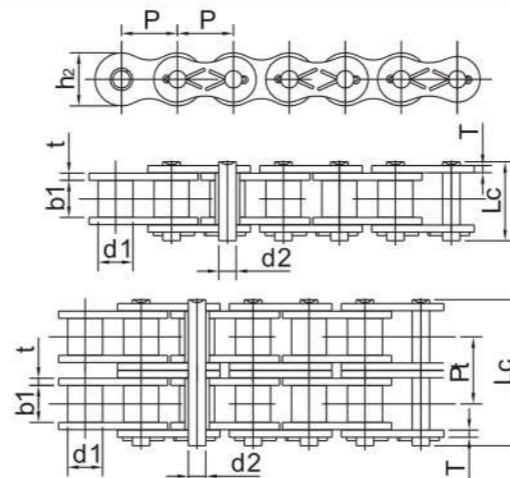

ISO/DIN 链号 Chain No.	ANSI 链号 Chain No.	节距 Pitch	滚子直径 Roller diameter	内节内宽 Width between inner plates	销轴直径 Pin diameter	销轴长度 Pin Length	内链板高度 Inner plate depth	排距 Transverse pitch	链板厚度 Plate thickness	抗拉强度 Ultimate tensile strength	平均抗拉强度 Average tensile strength	每米重量 Weight per meter
		P	d1 max	b1 min	d2 max	Lc max	h2 max	Pt	t/T	Q min	Q0	q =
		mm	mm	mm	mm	mm	mm	mm	mm	KN	KN	Kg/m
08AH-1	40H	12.70	7.95	7.85	3.96	19.70	12.00	-	2.00	13.9	20.40	0.82
10AH-1	50H	15.875	10.16	9.40	5.09	24.90	15.09	-	2.40	21.8	30.20	1.25
12AH-1	60H	19.05	11.91	12.57	5.96	31.60	18.08	-	3.20	31.3	42.70	1.87
16AH-1	80H	25.40	15.88	15.75	7.94	39.40	24.13	-	4.00	55.6	71.40	3.10
20AH-1	100H	31.75	19.05	18.90	9.54	46.90	30.17	-	4.80	87	112.4	4.52
24AH-1	120H	38.10	22.23	25.22	11.11	57.50	36.20	-	5.65	125	160.9	6.60
28AH-1	140H	44.45	25.40	25.22	12.71	62.50	42.23	-	6.45	170	217.3	8.30
32AH-1	160H	50.80	28.58	31.55	14.29	72.70	48.26	-	7.25	223	285.8	10.30
40AH-1	200H	63.50	39.68	37.85	19.85	93.50	60.33	-	9.50	347	444.5	19.16
12AH-2	60H-2	19.05	11.91	12.57	5.96	57.70	18.08	26.11	3.20	62.6	84.5	3.71
16AH-2	80H-2	25.40	15.88	15.75	7.94	72.20	24.13	32.59	4.00	112.2	145.3	6.15
20AH-2	100H-2	31.75	19.05	18.90	9.54	86.00	30.17	39.09	4.80	174	225.9	9.03
24AH-2	120H-2	38.10	22.23	25.22	11.11	106.4	36.20	48.87	5.65	250	322.7	13.13
28AH-2	140H-2	44.45	25.40	25.22	12.71	114.7	42.23	52.20	6.45	340	437.7	16.60
32AH-2	160H-2	50.80	28.58	31.55	14.29	134.9	48.26	61.90	7.25	446	571.6	20.20
40AH-2	200H-2	63.50	39.68	37.85	19.85	171.8	60.33	78.31	9.25	694	894.9	38.11
12AH-3	60H-3	19.05	11.91	12.57	5.96	83.84	18.08	26.11	3.20	93.9	113.9	5.54
16AH-3	80H-3	25.40	15.88	15.75	7.94	104.6	24.13	32.59	4.00	166.8	203.5	9.42
20AH-3	100H-3	31.75	19.05	18.90	9.54	125.1	30.17	39.09	4.80	261	314.8	12.96
24AH-3	120H-3	38.10	22.23	25.22	11.11	155.2	36.20	48.87	5.65	375	444.7	19.64
28AH-3	140H-3	44.45	25.40	25.22	12.71	166.9	42.23	52.20	6.45	510	598.4	24.90
32AH-3	160H-3	50.80	28.58	31.55	14.29	196.8	48.26	61.90	7.25	669	787.3	30.10
40AH-3	200H-3	63.50	39.68	37.85	19.85	250.1	60.33	78.31	9.25	1041	1228.2	57.05

环球 侧弯链
Side bow chains

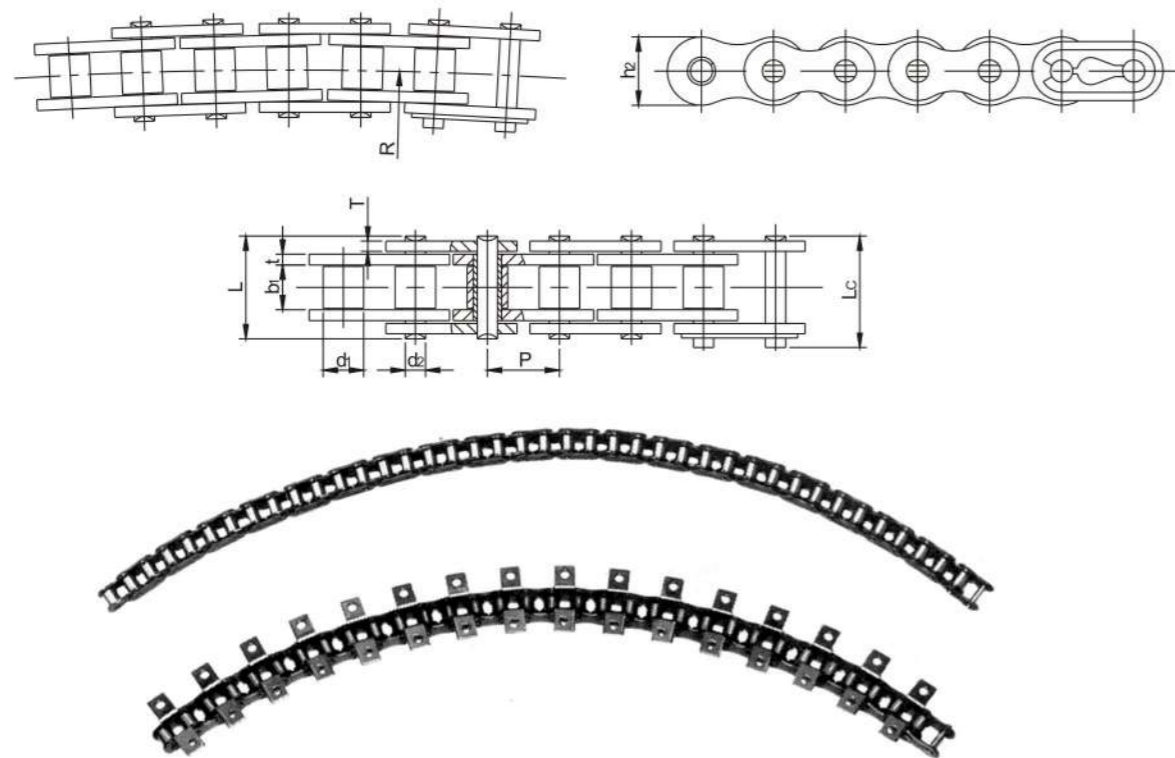

链号 Chain No.	节距 Pitch	滚子直径 Roller diameter	内节内宽 Width between inner plates	销轴 直径 Pin length	销轴长度 pin length		内链板 高度 Inner plate depth	链板厚度 Plate thickness	侧弯半径 Side bow radius	抗拉强度 Ultimate tensile strength	平均抗拉 强度 Average tensile strength	每米重量 Weight per meter
					L	Lc						
					max	max						
40SB	12.7	7.95	7.85	3.96	16.90	18.10	11.70	1.50	350	13.80/3136	15.20	0.80
43SB	12.7	7.95	7.85	3.45	18.30	19.50	11.70	1.50	305	12.00/2727	13.20	0.64
50SB	15.875	10.16	9.40	4.37	20.70	22.70	15.09	2.00	400	20.60/4681	22.70	1.09
60SB	19.05	11.91	12.57	5.34	26.60	28.40	18.10	2.40	500	15.70/3568	17.30	1.42
63SB	19.05	11.91	12.68	5.08	28.80	30.60	17.20	2.4/2.0	350	12.50/2840	20.00	1.40
80SB	25.40	15.88	15.75	7.19	34.00	37.30	24.00	3.20	711	40.90/9201	42.00	2.60
08BSB	12.70	8.51	7.75	3.97	17.40	18.70	11.80	1.60	400	14.00/3182	15.40	0.70
08BSBF1	12.70	8.51	7.75	3.97	16.30	17.60	11.80	1.6/1.2	400	12.80/2909	14.10	0.65
10BSB	15.875	10.16	9.65	4.50	20.10	21.50	14.70	1.70	400	15.60/3545	17.20	0.93
12BSB	19.05	12.07	11.68	5.12	23.10	24.80	16.00	1.85	500	20.50/4658	22.60	1.16
16BSB	25.40	15.88	17.22	7.90	36.50	39.70	21.00	3.7/3.0	500	55.6/12635	64.00	2.53
C2050SB	31.75	10.16	9.40	5.08	21.30	22.60	15.00	2.03	800	21.80/4954	24.10	0.84

推窗链 (反侧弯链) 环球
Pushing window chains (anti-side bow chains)

防弯链
Anti-side Bow Chains

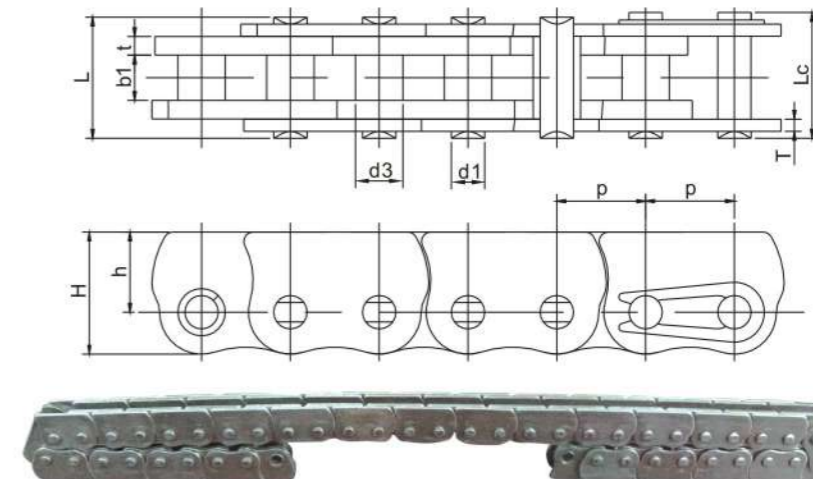

环球链号 Universal Chain No	节距 Pitch	套筒直径 Bush diameter	内节内宽 Width between inner plates	销轴直径 Pin diameter	销轴长度 Pin Length		链板尺寸 Plate dimension			抗拉强度 Ultimate tensile strength	每米重量 Weight per meter
					L	Lc	H	h	t/T		
					max	max	max	mm	max		
SPC9.525	9.525	5.08	4.68	3.58	13.1	14.6	13.1	8.6	2/1.3	10.8	0.73

推窗链
Pushing Window Chains

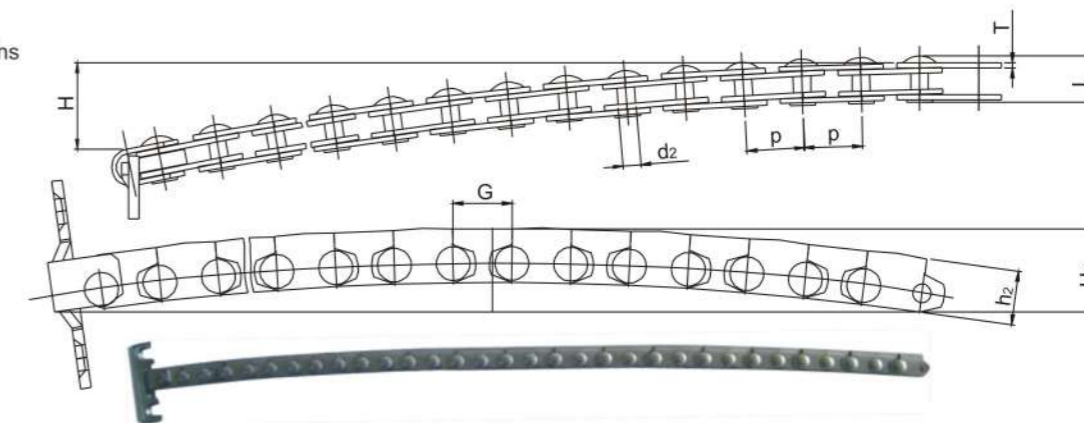

环球链号 Universal Chain No	节距 Pitch	销轴直径 Pin diameter	销轴长度 Pin Length	链板尺寸 Plate dimension			链板尺寸 Plate dimension		每米重量 Weight per meter
				h2	G	T	H	H2	
				max	max	max	max	max	
SPC12.65a	12.70	3.9	9.80	11.95	12.80	1.1	50 ~ 80	17.0	0.33
*SPC12.65	12.70	3.9	9.80	11.95	12.80	1.1	55 ~ 75	17.0	0.33

注: *为不锈钢链
Note: *stainless steel chains